

**Barber
Lateral Motion Devices
and
Side Bearings**

The function of Barber Lateral Motion Devices is to provide a reliable and simple means to accommodate the sidewise movement of a car body, without imposing excessive stress upon wheel flanges, truck side frames or upon any of the adjacent parts. The device is a simple and practical substitute for "swing hangers."

All passenger car trucks have provision for lat-

fore provides effective protection against many of the common causes of derailments, freight damage claims, and delays for repairs.



Fig. 2211—Barber Lateral Motion Device Dismantled

eral motion through some type of swing hanger. At one time swing hangers were extensively used on freight car trucks, but were discontinued because excessive wear soon put them in a dangerous condition. A defective hanger in a moving truck nearly always resulted in a serious wreck.

The same easy-riding qualities, so desirable for passenger equipment, are possible for freight cars by the use of the Barber Lateral Motion Device. As a result wear and tear are decreased and delays, accidents, or actual money losses inseparably associated with wrecks and tie-ups are reduced or eliminated, for the Barber Lateral Motion Device disposes of one of the principal danger elements in truck construction.

Some of the advantages realized through the use of the Barber Lateral Motion Device include decreased wheel-flange wear, rail wear, and lower train resistance. Other parts which suffer where ordinary equipment is used, but which give less trouble when freight cars are equipped with the Barber Lateral Motion Device, are the coupler knuckles and journal brasses. This device there-

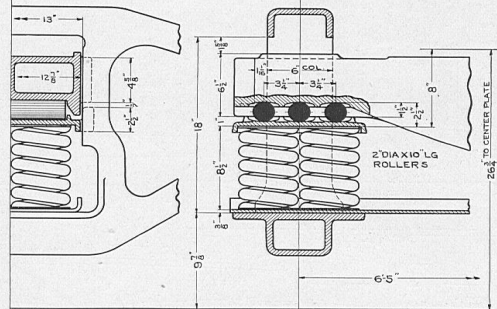

Fig. 2212—Barber Lateral Motion Truck Device for A. R. A. 50-Ton Truck

Barber No. 17 Adjustable Roller Side Bearings are designed to meet new conditions and to fill a long-standing want. The difficulty of producing body and truck bolsters of modern construction to given dimensions has created a demand for side bearings that are adjustable. The variation in side bearing clearance has always made that type of side bearing desirable.

The Barber No. 17 Roller Side Bearing shown in Fig. 2213 meets all requirements with an adjustable range of $\frac{5}{8}$ in. The height of this bearing can be reduced or increased without jacking up the car or without the use of tools, the shim retainer for common sheet steel shims being the only extra part added to the simple construction of the popular No. 11 Barber Bearing.

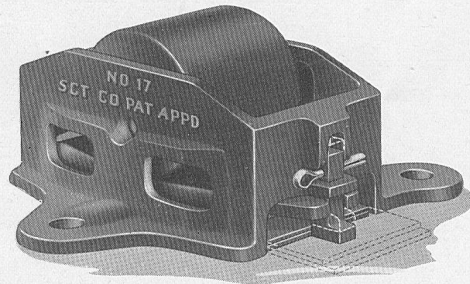

Fig. 2213—The Barber No. 17 Adjustable Roller Side Bearing

The housing is of electric steel. The bearing plate and roller are drop forged and heat treated. All parts are held in one unit for shipment and cannot be displaced after bearing is secured to truck. Ample capacity, long wear and continuous service are assured.

The Barber Combination Side Bearing and Body Arch, illustrated in Figs. 2347 and 2348, page 816, has been developed especially for the newest designs of passenger cars having cast steel underframes.

For other products and branch offices, see classified and alphabetical indexes.

STANDARD CAR TRUCK COMPANY, CHICAGO, ILL.